

10YBQ-F



AVAILABLE MOUNTING CONFIGURATIONS

- 10YBQ-F-RP REDI-PRIME FRAME MOUNT
- 10YBQ-F FRAME MOUNT
- 10YBQ-RP-EM REDI-PRIME ENGINE MOUNT
- 10YBQ-EM ENGINE MOUNT
- 10YBQ-VM VERTICAL CLOSE COUPLED
- 10YBQ-VF VERTICAL FRAME MOUNT
- 10YBQ-VC VERTICAL COUPLED
- 10YBQ-CC CLOSE COUPLED

OPERATING LEVELS

MIN FLOW	900 GPM	204.41 m ³ /h
MAX FLOW	6900 GPM	1567.16 m ³ /h
DISCHARGE SIZE	10"	254 mm
SUCTION SIZE	10"	254 mm
MAX SPEED	2400 RPM	2400 RPM
SOLIDS HANDLING	1.38"	35.05 mm
MAX PRESSURE	150 PSID	1,034.21 kPa
SHUT-OFF HEAD	207' @ 89.61 PSID	63.09 m @ 617.84 kPa
BEP HEAD	125' @ 54.11 PSID	38.1 m 373.08 kPa
BEP FLOW	5,300 GPM	1203.76 m ³ /h
BEP PERCENT	77%	77%

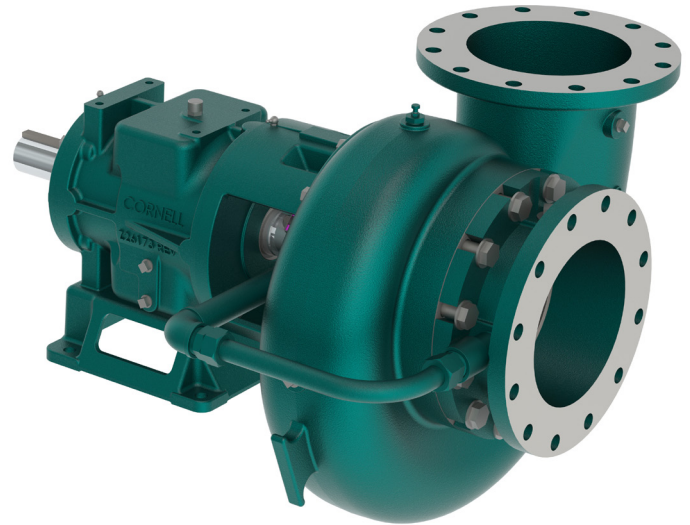

A typical picture of the pump is shown. Please contact Cornell Pump Company for further details. All information is approximate and for general guidance only.

PARTS	CAST IRON BRONZE FITTED	ALL IRON
WEAR RING	BRONZE SAE 660	CAST IRON ASTM A48 CL30
IMPELLER	CAST IRON ASTM A48 CL30	CAST IRON ASTM A48 CL30
VOLUTE	CAST IRON ASTM A48 CL30	CAST IRON ASTM A48 CL30
SHAFT	SAE 1144 "STRESSPROOF" STEEL	SAE 1144 "STRESSPROOF" STEEL
SHAFT SLEEVE	BRONZE SAE 660	416 STAINLESS STEEL
PACKING	GRAPHITED ACRYLIC	GRAPHITED ACRYLIC
MECHANICAL SEAL	T-1 BUNA, CARBON/CERAMIC/STAINLESS	T-1 VITON, CARBON/CERAMIC/STAINLESS
BACKPLATE	CAST IRON ASTM A48 CL30	CAST IRON ASTM A48 CL30
BEARING FRAME	CAST IRON ASTM A48 CL30	CAST IRON ASTM A48 CL30

The 10YBQ pump is designed with Cornell's renowned quality and durability. It features a 10" discharge, 10" suction, enclosed multi-vane impeller, and flanged tangential double volute. Available in standard Cast-Iron Bronze Fitted or All Iron. Optional Redi-Prime or Venturi Prime priming system is available. Pump end mounts to F18, EM18, F18DB & EM18DB bearing frames. Bearings are heavy-duty, grease lubricated, single or double ball bearings with a minimum of 20,000 hours bearing life.

- Industry-leading two-year warranty
- Industry-leading efficiencies
- External hydraulic balance line
- Replaceable suction wear rings and shaft sleeve
- Grease lubrication standard - oil optional
- Heavy-duty modular bearing frame
- Large shaft and bearings
- RunDry™ option (Indefinite run dry capability)
- Optional Cycloseal® with T-1 mechanical seal
- SAE #3, 4 & 5 engine mount available



AGRICULTURE



FOOD



INDUSTRIAL



MINING



MUNICIPAL



OIL & GAS



REFRIGERATION



RENTAL

10YBQ-F

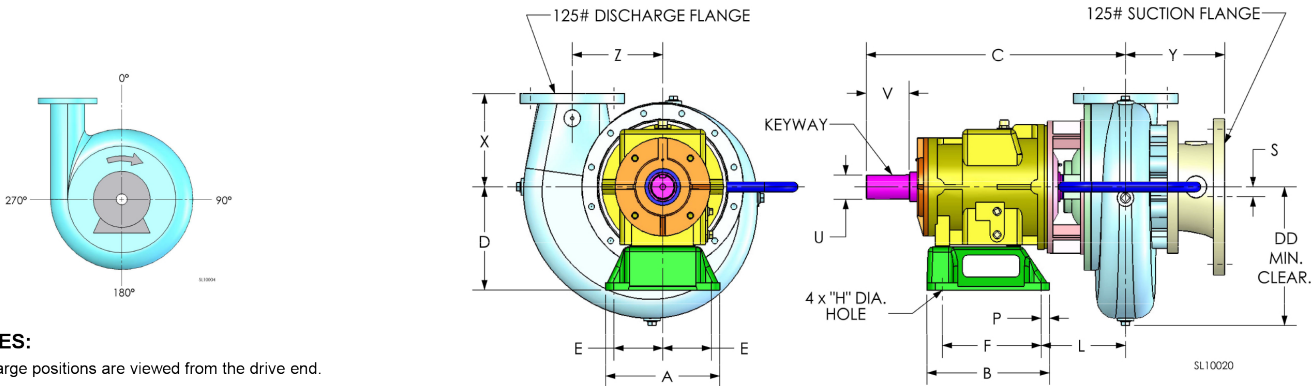

NOTES:

Discharge positions are viewed from the drive end.
Standard increments of discharge position are shown in the chart below (DISCH INCR). Consult factory for other discharge positions.

NOTES:

1. "V" Dimension is maximum useable shaft.
2. Frame mounting foot thickness is .75".
3. Flange connection dimension can vary ± .12 inch.
4. Do not use for construction unless certified.

PUMP DIMENSIONS																					
MODEL	FRAME	CONNECTION		DISCH. INCR.	A	B	C	D	DD	E	F	H	L	P	S	U	V	X	Y	Z	KEYWAY
		DISCH.	SUCT.																		
10YB	F18/DB	10	10	90°	12	12.88	30.77	10.5	18.25	5.12	10.38	0.81	12.41	0.88	-	2.5	4.5	11	10.7	12.5	.62X.31
10YBQ	F18/DB	10	10	90°	12	12.88	30.77	10.5	18.25	5.12	10.38	0.81	12.41	0.88	-	2.5	4.5	11	10.7	12.5	.62X.31

